

McGill AirSilence LLC

An enterprise of United McGill Corporation —
Founded in 1951

Assembly Instructions

SOUNDSCREEN™

Snap-Lock and Tongue-and-Groove
Insulated Panel Systems

a McGill AirSilence™ product

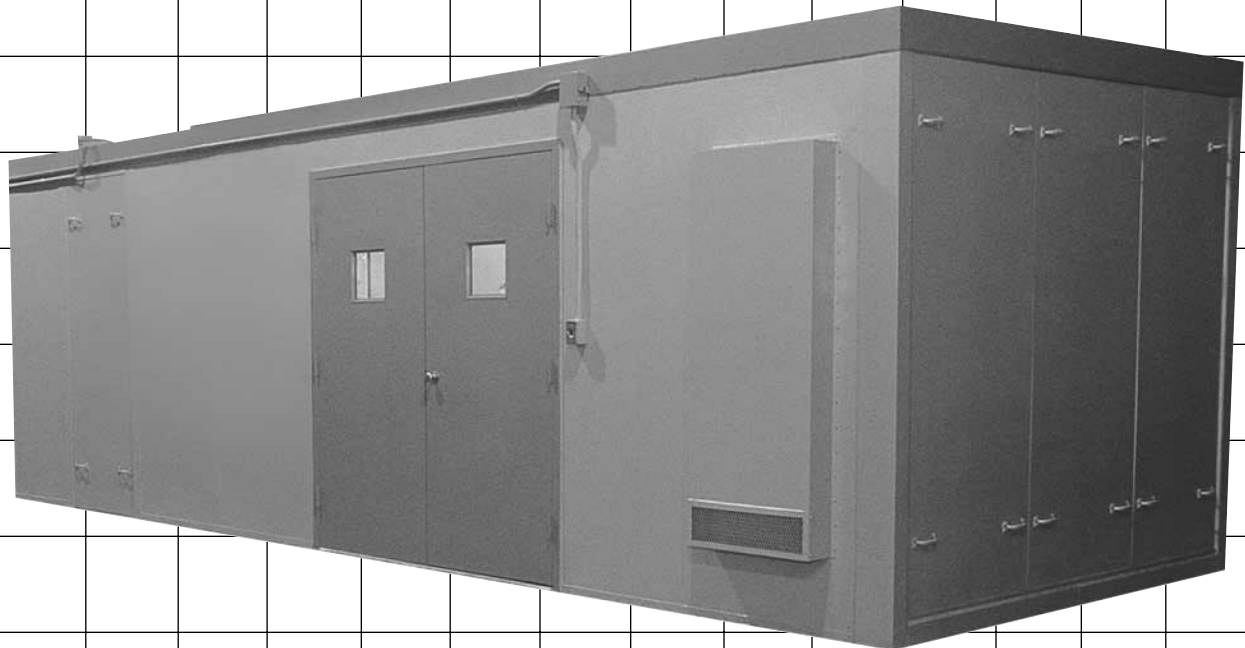

Read this brochure completely before beginning erection of the panel system. Assembly procedures for the 2-inch and 4-inch panel systems are identical. Careful adherence to these procedures will simplify erection and ensure a leak-proof assembly. Any material shortages must be communicated to McGill AirSilence LLC within 72 hours of delivery to the jobsite.

Planning Hints and Notes

1. Review the McGill AirSilence erection drawings prepared specifically for the job.
2. A material identification system is listed at the end of this brochure. Use this to determine the various parts of the panel system as it is detailed on the erection drawings.
3. In addition to the material identification system, a color coding system is used if there is more than one housing at the jobsite. Envelopes attached to the bulkhead clearly list the color code and unit location. Instruct the unloading crew about the color coding system so mixups and confusion can be avoided.
4. Before the truckload of panels arrives, clear the area near where the panels are to be erected so they can be conveniently stored. To save time and labor in handling the panels, move panels directly from the truck to this area. Make sure the necessary material handling equipment is available, including lifts for getting the panels off the truck and onto the proper floor and carts to move the panels to the erection site.
5. When panels are stored near the erection area, stack them on end and lengthwise. This will save time moving and restacking panels as the housing is erected. If more than one housing is involved, separate and stack panels by color code.
6. Assemble a complete set of required tools and equipment to complete the panel system installation. Depending on the nature of the job, the following items may be required:

- welding and cutting equipment
- ladder
- extension cord
- drill masters and self-drilling screw-driving head
- duct lifts
- portable lighting
- masonry drills
- metal-cutting saws
- steel tape measure
- come-along
- sealer gun

General Notes

1. Where sealer is called for in the erection of the panel system, use a 1/4-inch bead of McGill AirSeal's UNI-WEATHER™ sealer to properly seal joints. McGill AirSilence will specify the location of the sealer; however, the sealer is to be provided by the installing contractor.
2. All base channel and outside trim is prepunched for #10 x 3/4-inch sheet metal screws on 6-inch centers. Sheet metal screws are supplied with each panel system. McGill AirSilence will provide a number of #10 x 3/4-inch sheet metal screws equal to approximately 5 times the total lineal feet of all panel system trim and base channel. This number should be adequate, but there is no guarantee that it will be enough for any specific job or customer.

Important

Sheet metal screws are not needed in McGill AirSilence's snap-lock panel joints (see **Detail 1**) unless specifically called for in the erection drawings. However, sheet metal screws are required for McGill AirSilence's tongue-and-groove panel joints (see **Detail 2**).

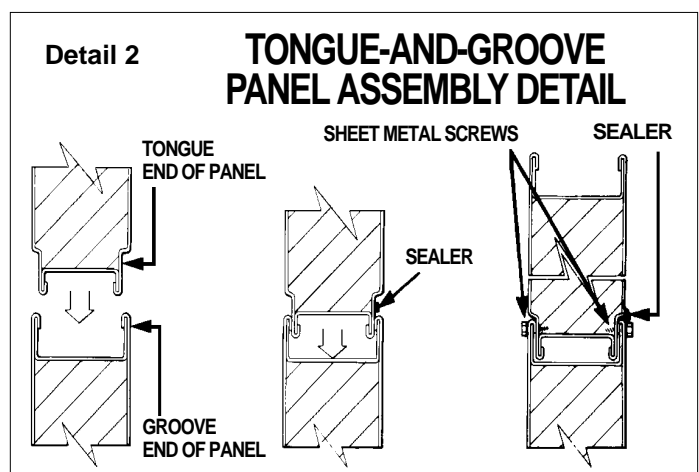
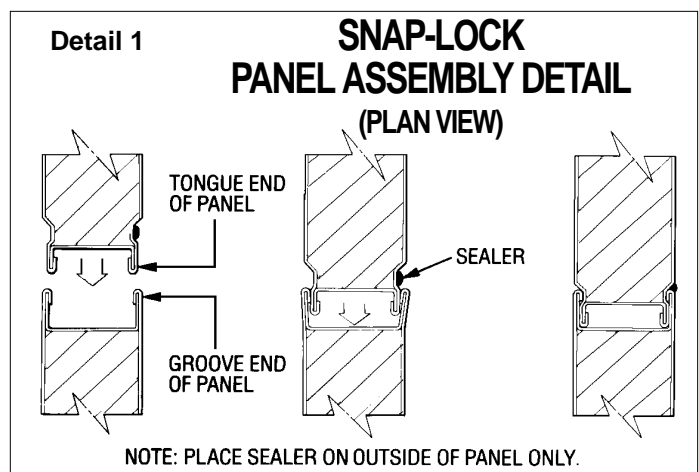

Step One:

Installation of Base Channel

1.A. Check curb and/or base to be sure it is square, level, and in accordance with approved dimensions. Problems may arise later if the curb is not properly installed.

1.B. Apply two parallel beads of sealer on curb or floor, spacing sealer so both beads will be under base channel when it is installed. Do not apply more sealer at one time than will be covered by base channel within 15 minutes (see **Details 3** and **4**).

1.C. Starting at the corner where the first panels will be erected (see McGill AirSilence erection drawings—starting point will be noted as **Erect 1**), miter the base channel, forming a corner, and secure the channel with drive nails on 18-inch centers (see **Detail 4**).

The drive nail centerline is shown on the curb plan for the housing. This is also the centerline of the base channel. Drive nails (or anchor bolts) **must** be located on this centerline so they will not be under an edge of a panel. If anchor bolts are used, locate 5/16-inch-diameter anchor bolts on 18-inch centers with 3/8-inch bolt projection above the curb. Locate bolts as curb is being poured.

The base channel is furnished in 12-foot lengths, to be cut as necessary in the field. Sections of base channel should fit tightly together.

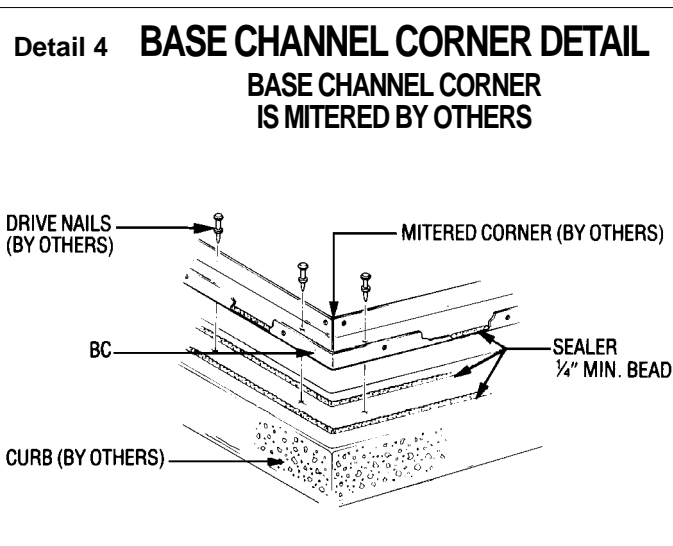
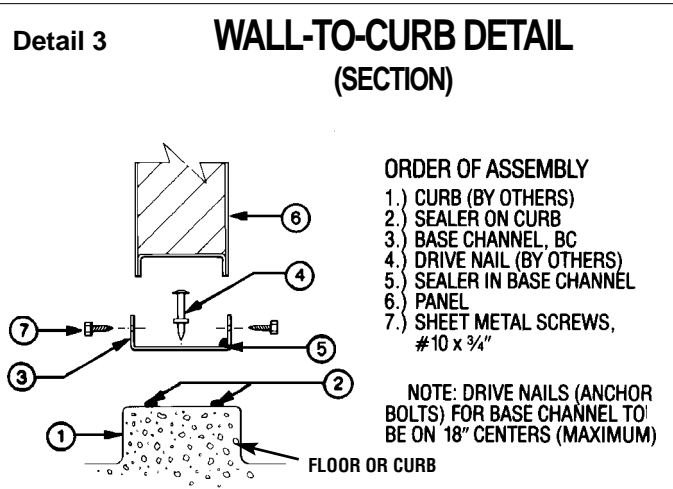

The products depicted in this booklet were current at the time of publication. As a quality-conscious manufacturer, McGill AirSilence continually seeks ways to improve its products to better serve its customers. Therefore, all designs, specifications, and product features are subject to change without notice.

Step Two:

Erection of Wall Panels

2.A. Starting at this same corner (marked **Erect 1** on the McGill AirSilence erection drawings), apply sealer as a fillet along the interior outside edge of the base channel as shown in **Details 3** and **4**.

2.B. Insert panels that form the first corner into base channel (see **Detail 5**). It is important to note on the erection drawings which panel is positioned first in the mitered base channel corner.

2.C. Secure base channel to corner panels with #10 sheet metal screws (see **Details 3** and **5**).

2.D. Cut outside trim for the first corner. Apply sealer to the outside trim. Position the trim and attach with #10 sheet metal screws (see **Details 5** and **6**).

2.E. From this corner, run a tape measure along the base channel for the two walls that extend outward from this corner, and place a mark on the outside edge of the base channel at all panel width increments. Use panel dimensions on the erection drawings (see **Figure A**).

2.F. In the following manner, erect wall panels for the two walls extending outward from this corner:

2.F.1. Place sealer on curb for the next section of base channel and install base channel. Apply sealer along the interior outside edges of base channel.

2.F.2. Place sealer in recessed groove on outside face of tongue panel (see **Detail 5**).

2.F.3. Insert tongue panel into base channel and seat into previous groove panel with come-along and closure tool (supplied by others) detailed in **Figure B**.

All panels must be properly sealed to permit a proper fit and thereby minimize the possibility of growth in the length or shrinkage of the wall (see **Detail 1**). Panel dimension tolerance on the width is $\pm 1/16$ inch.

2.F.4. As each panel is installed, the mark previously placed on the base channel (step 2.E.) will verify the location of each panel joint. If a panel joint does not line up with a mark, double check panel dimensions and panel markings with erection drawings and make necessary corrections.

2.F.5. As each wall (and partition) panel is installed, secure the base channel to each wall panel with sheet metal screws.

2.G. Follow the erection sequence on the erection drawings and install all wall and partition panels by repeating steps 2.F.1. through 2.F.5.

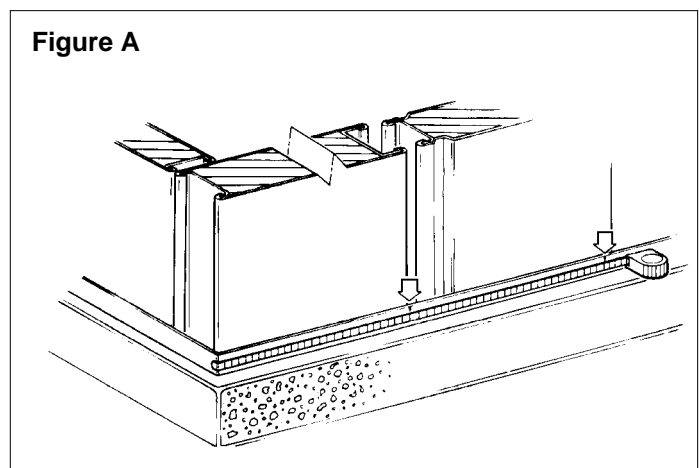
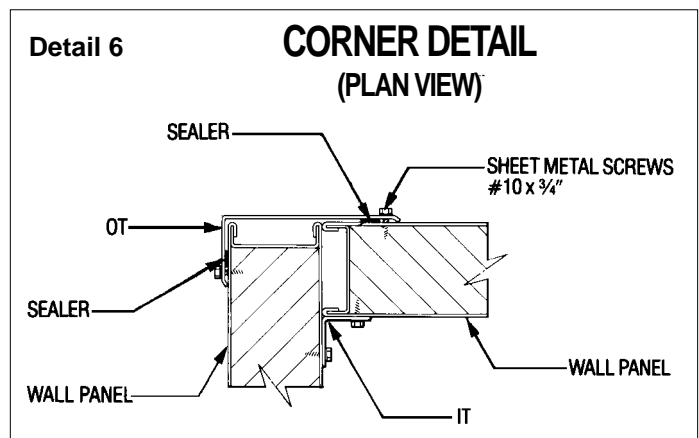
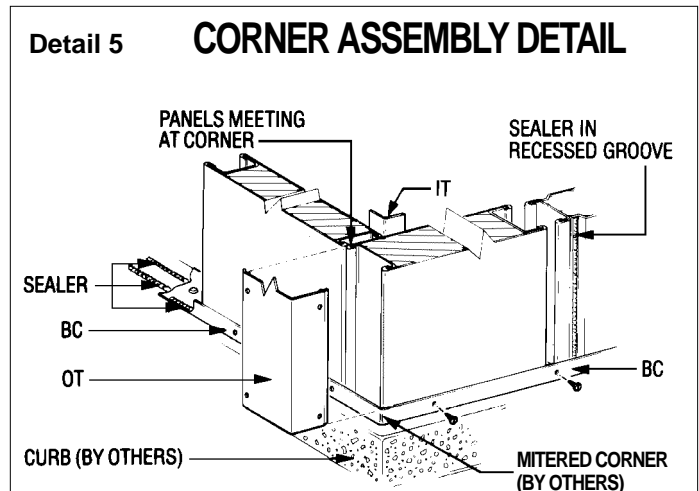
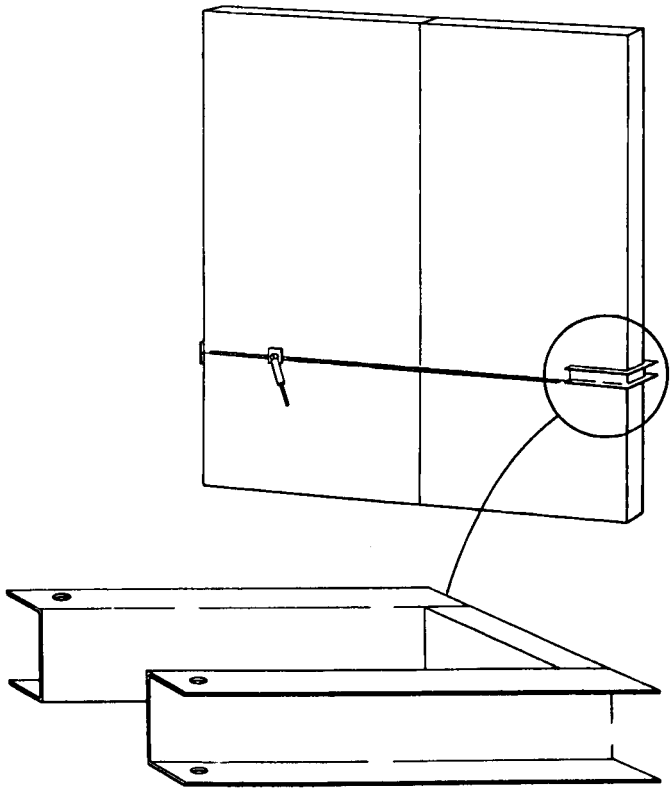

Figure B



(SUGGESTED CLOSURE TOOL IS SUPPLIED BY OTHERS.)

Septum Panels

Septum panels are either 2 inches or 4 inches thick with perforated metal on both sides and a solid metal divider in the middle. They are used as partitions where an acoustical panel is desired on both sides of the partition and where a pressure differential exists which would cause leakage through the perforated metal if there were no solid divider in the panel. They can also be used to separate the hot and cold deck of the housing.

Door Panels

Seat panels in the same manner as regular panels.

Typical Construction Details

Detail 9 WALL PANEL TO BLDG. WALL (PLAN VIEW)

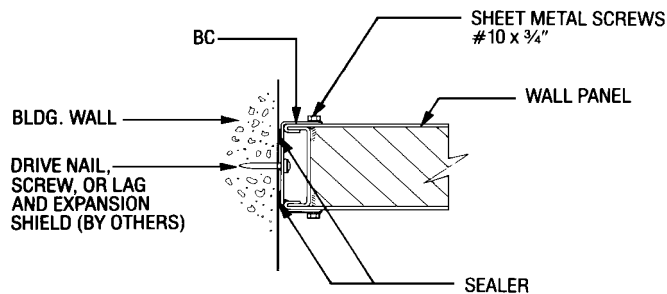

Detail 16 90° WALL OFFSET

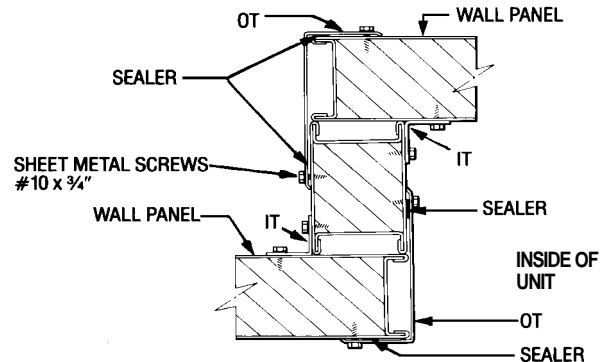

Detail 11 WALL PANEL TO BLDG. CEILING (ELEVATION VIEW)

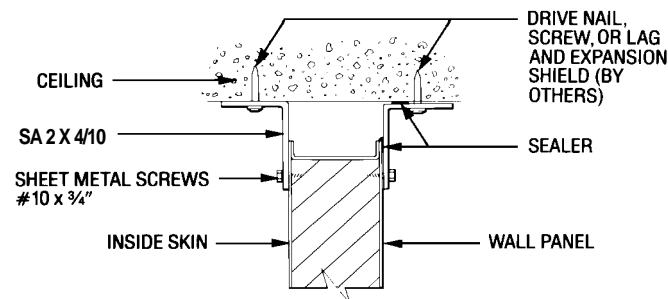

Detail 24 DRIP SHIELD DETAIL

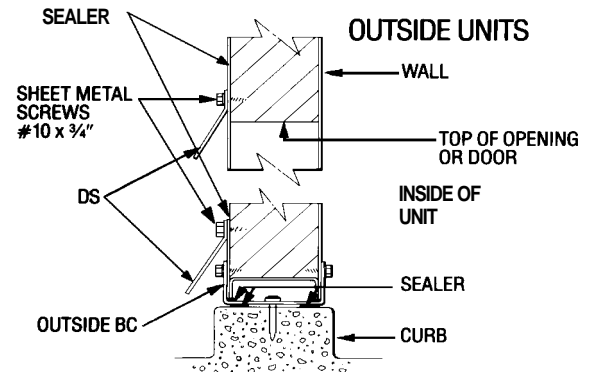

Detail 12 SPECIAL OUTSIDE TRIM DETAIL (ELEVATION VIEW)

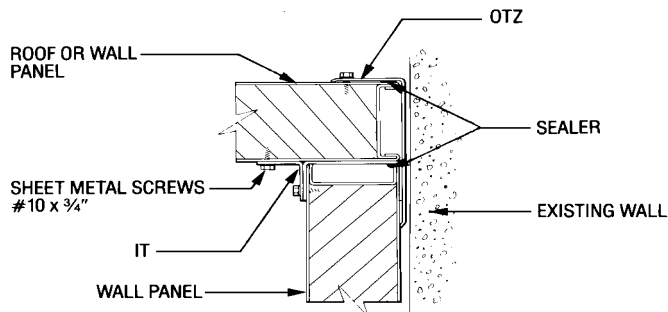

Detail 25 EQUIPMENT BLANK-OFF TO PANEL WALL

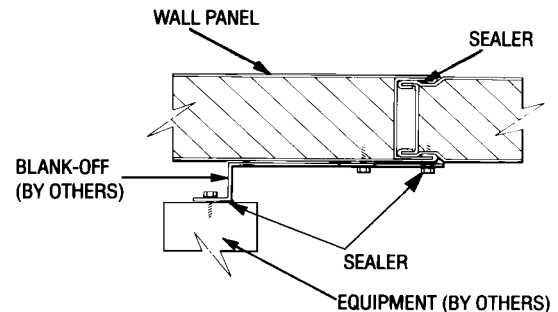

Detail 13 INTERIOR PANEL CONNECTION (WALL-TO-WALL AND WALL-TO-ROOF CONNECTION, SIMILAR)

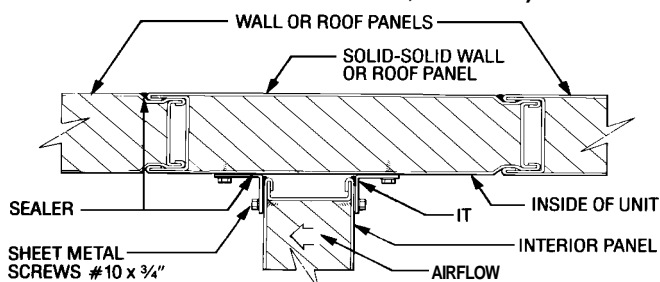

Detail 26 OPENING THROUGH PANEL (SECTION)

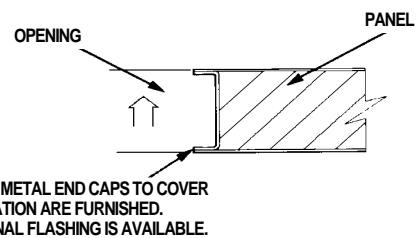

Step Three: Erection of Roof Panels

Typical Construction Details

- 3.A.** Review the roof plan on the McGill AirSilence erection drawings and locate roof panels and joining H strips (if required).
- 3.B.** Following the erection sequence on the erection drawings, place sealer in the recessed groove on the outside face of each tongue roof panel.
- 3.C.** Completely seat tongue roof panel into adjacent groove roof panel using a come-along and closure tool as detailed in **Figure C**.
- 3.D.** If joining H strips are shown on the erection drawings, place four beads of sealer in each H strip and secure to roof panels with #10 sheet metal screws as shown in **Detail 20**.

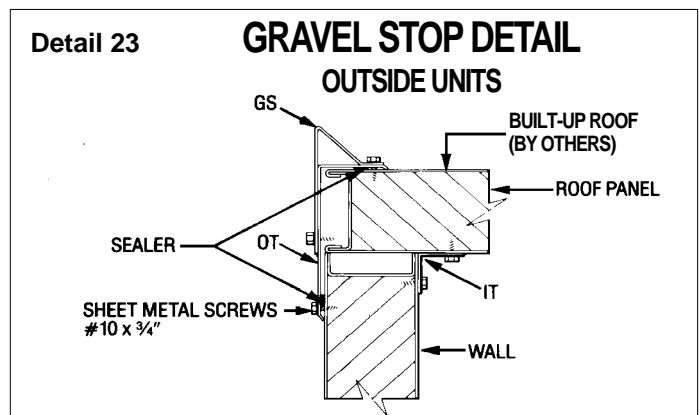
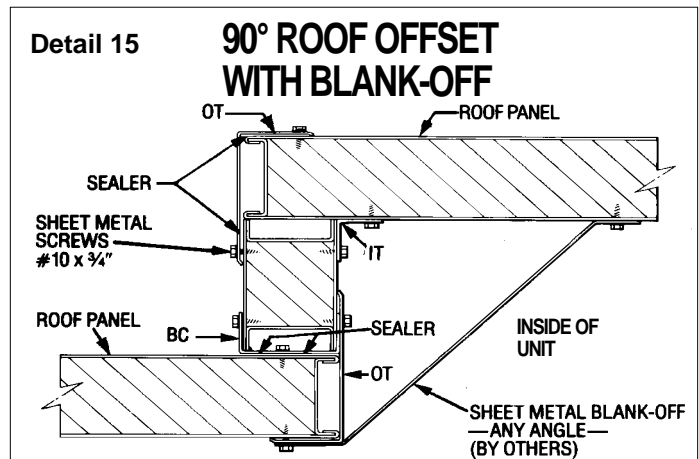
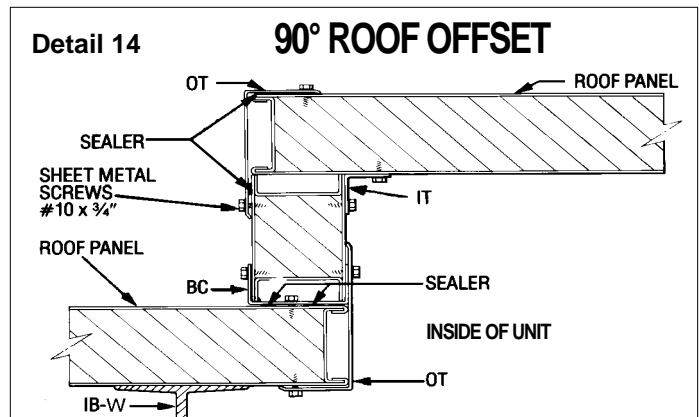
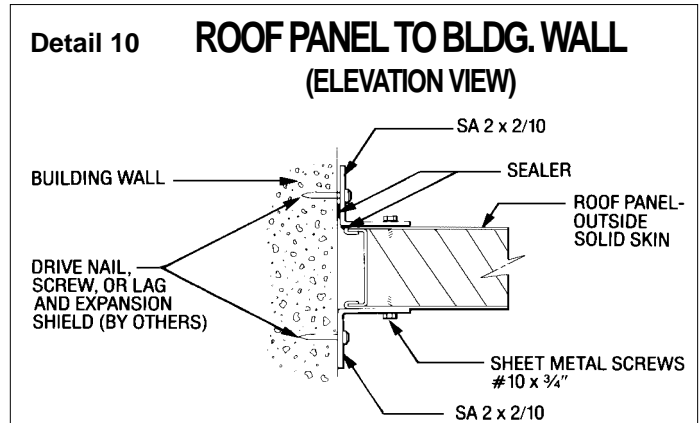
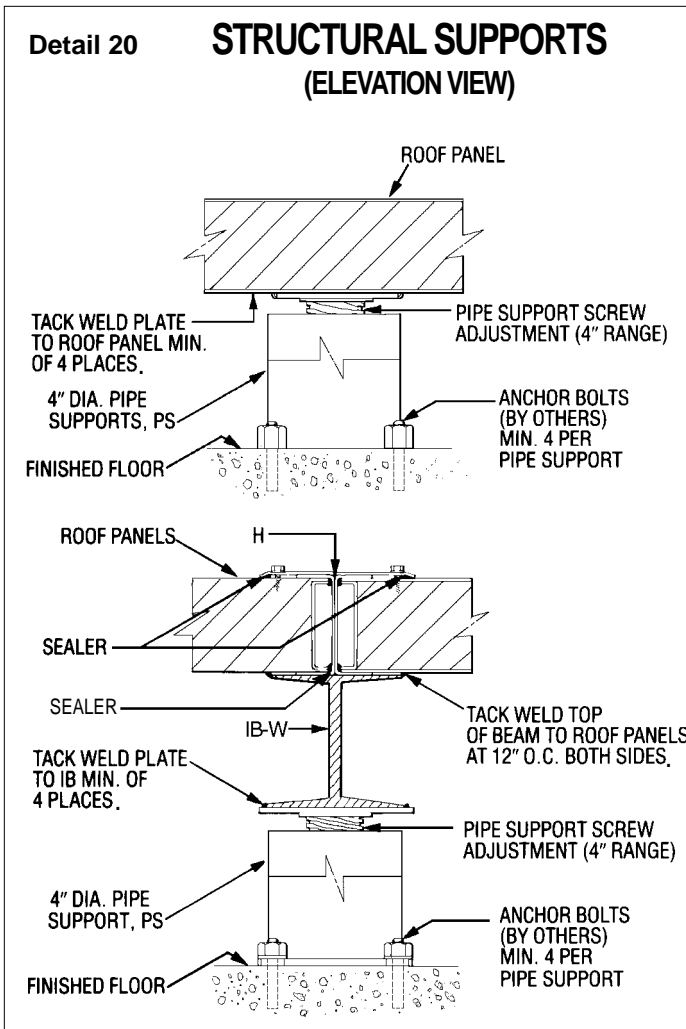

Step Four: Installation of Trim

4.A. After all wall and roof panels have been installed, secure outside trim corners as shown in **Details 7** and **8**. Sealer must be placed under trim corners where shown. Outside trim corners are prepunched.

4.B. Cut all outside trim (panel corners and panel-to-roof corners) to proper dimensions, apply sealer, position trim, and attach with #10 sheet metal screws as shown in **Details 5, 6, and 7**. The outside trim is prepunched and shipped in 12-foot lengths to be cut in the field as required.

4.C. After **all** outside trim has been installed, finish housing by installing inside trim at wall-to-wall and wall-to-roof corners (see **Details 5, 6, and 7**). The inside trim is shipped in 12-foot lengths to be cut in the field as required. It is **not** prepunched. Contractor must drill and anchor inside trim at all tongue-and-groove panel joints and at all internal panel stiffeners.

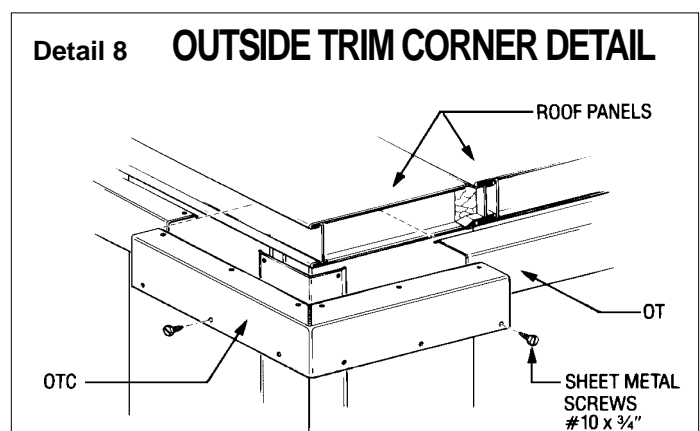
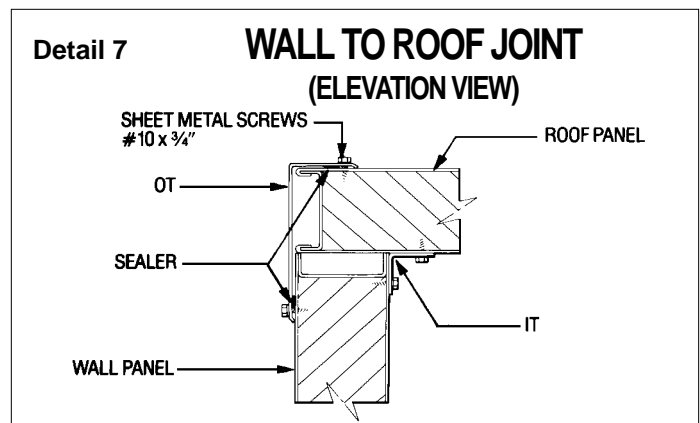
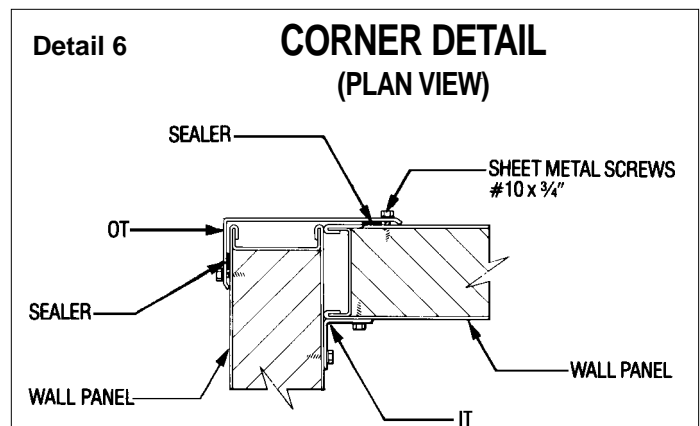
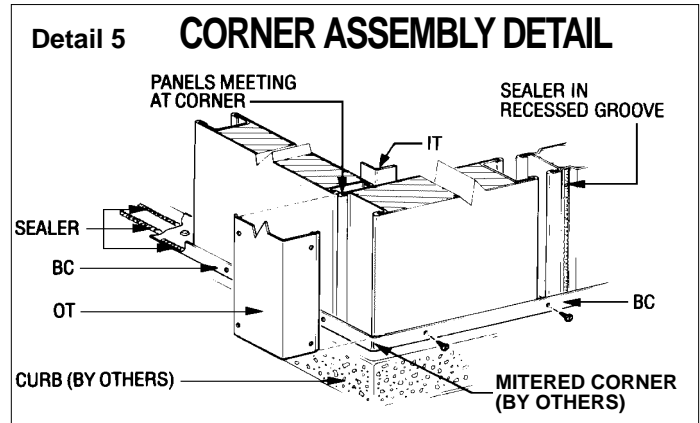

Special Assembly Considerations

Panels are sometimes used as the floor of the enclosure or as intermediate deck panels. If either of these situations exists in a panel system, it will be shown on the McGill AirSilence erection drawings. Special procedures for these installations are outlined below.

Floor Panels

1. Assemble floor panels following the procedure previously described for roof panels (steps 3.A. through 3.D.).
2. It may be necessary to place floor-to-wall corner trim before positioning floor panels (see **Detail 19**).
3. After floor panels are installed, install base channel on top of floor panels using #10 sheet metal screws as shown in **Detail 19**.
4. Erect remainder of housing, following the procedure outlined in steps 1.A. through 4.C.

Intermediate Deck Panels

1. After wall panels have been erected up to the deck level, install deck panels in the same manner described for roof panels. See McGill AirSilence erection drawings for details on locating deck panels on supporting structure.
2. After deck panels are in place, install base channel on deck panels using sheet metal screws as shown in **Detail 17**.
3. Install upper wall panels as outlined in steps 2.A. through 2.F.5.
4. Install special cover plate at joint between deck panels and wall panels as shown in **Detail 17**.
5. Install roof panels as outlined in steps 3.A. through 3.D. (see **Detail 18**).

Detail 17 INTERMEDIATE DECK DETAIL (ELEVATION VIEW)

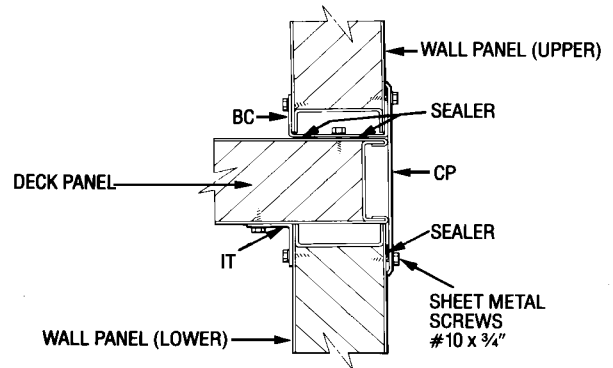

Detail 18 SPECIAL DECK TRIM DETAIL

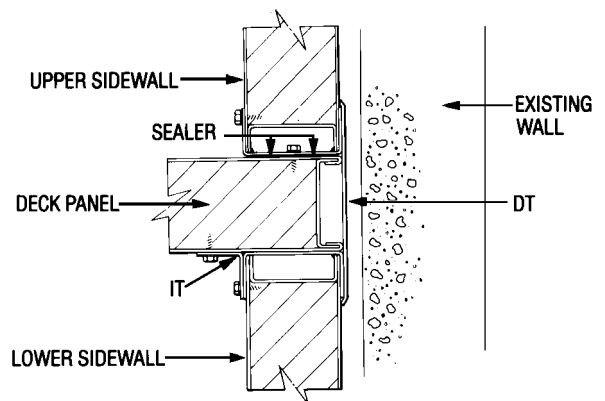

Detail 19 FLOOR PANELS

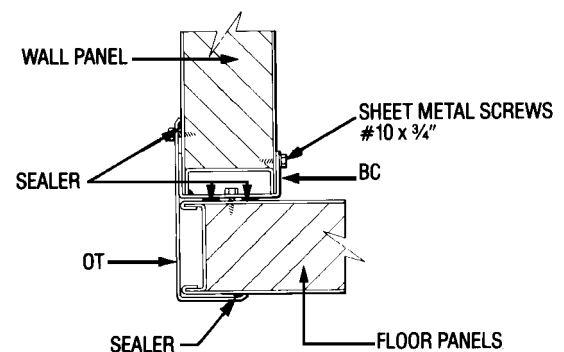

Factory Openings

If a factory opening is required, a channel will have been installed in the panel edge adjacent to the opening to retain the insulation (see **Details 21, 26, and 27**).

Steel Requirements

If roof spans are greater than 12 feet, structural steel bracing may be required. If so, the structural steel will be detailed on the McGill AirSilence erection drawings and should be installed according to the instructions (see **Detail 20**).

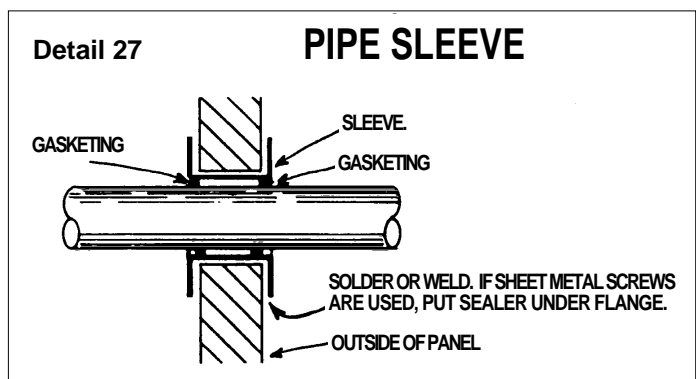
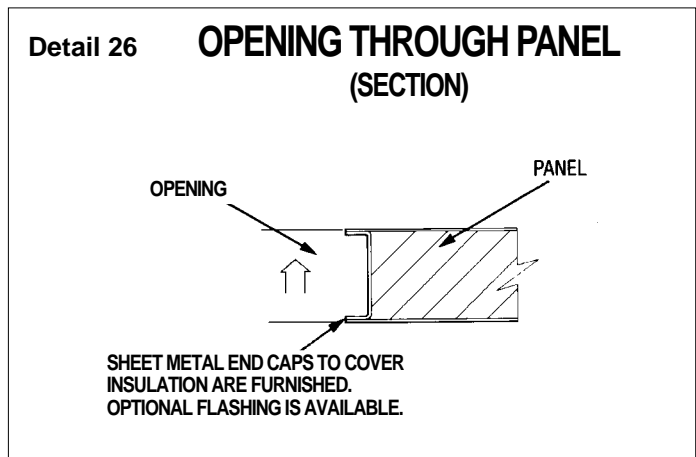
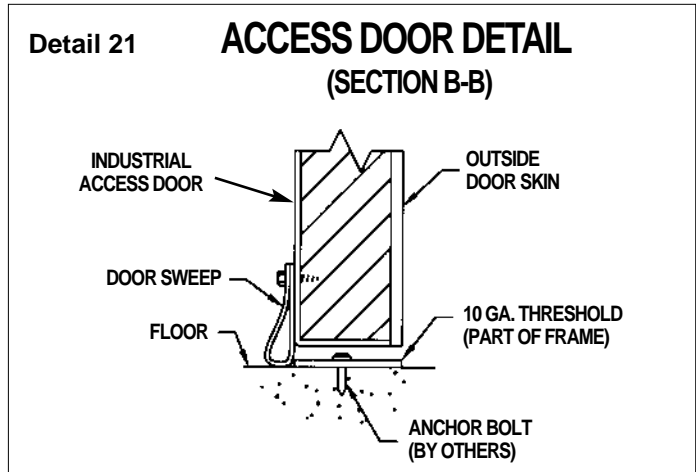
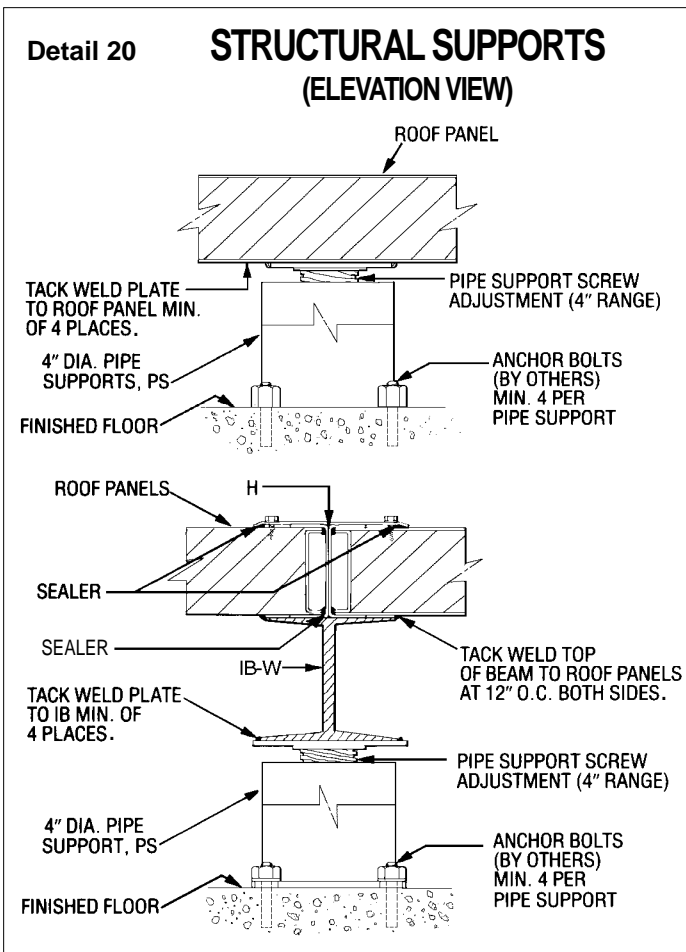

Installation Sequence

1. Locate base channel.
2. Set corner panels.
3. Install wall, partition, and door panels.
4. Add wall trim – outside and inside.
5. Add structural steel (as required).
6. Add roof panels.
7. Add roof trim – outside and inside.
8. Complete enclosure.

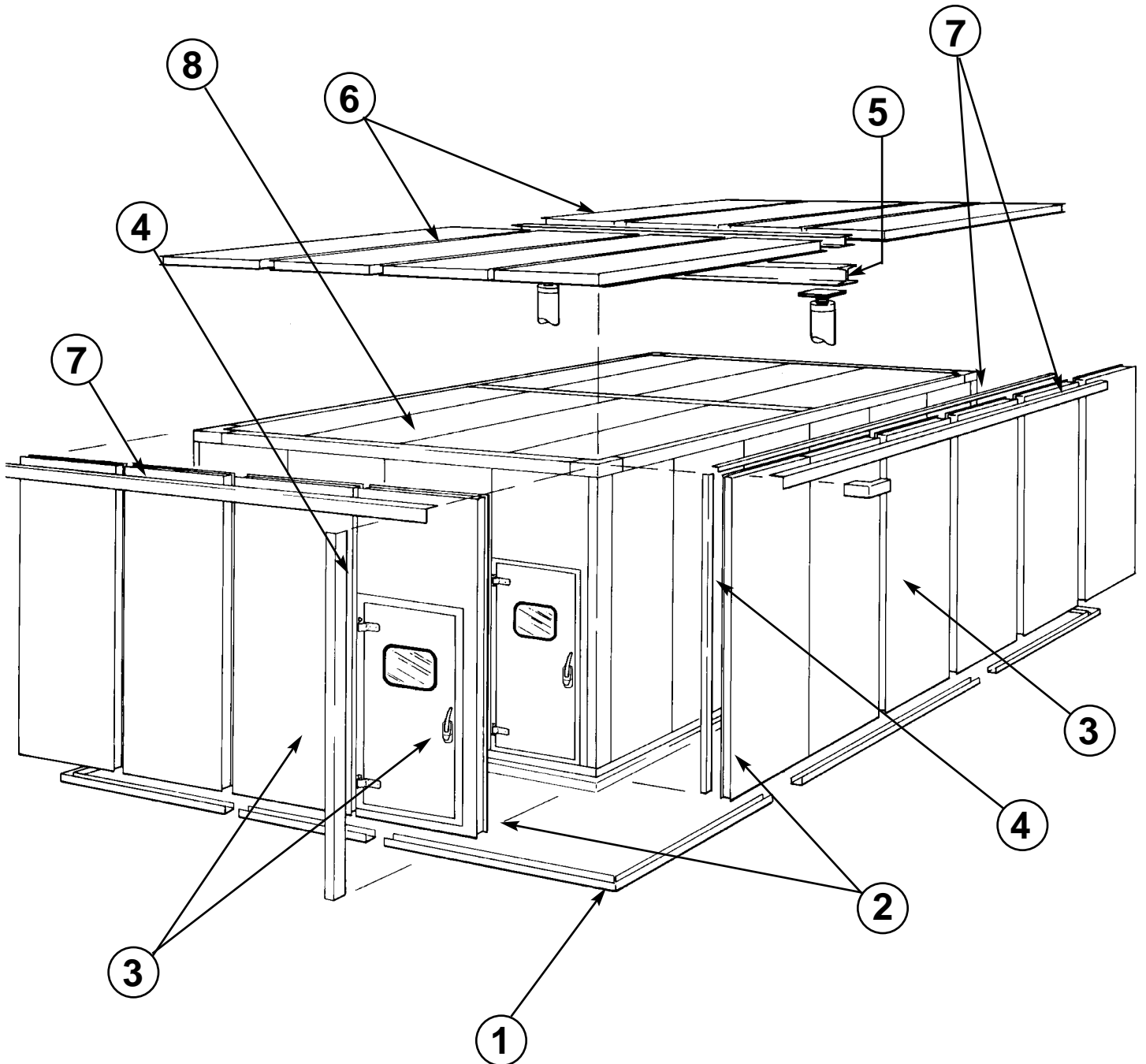

Panel System Material Identification

Part Identification	Part Description	Standard Size	Standard Length
Standard Trim Items			
IT	Inside trim— roof and wall panel corner	1 1/2" x 1 1/2"	12'
OT	Outside trim— roof and wall panel corner	3" x 7"	12'
BC-*	Base channel	4" panel—1 1/2" x 4 5/32" 2" panel—2 1/2" x 2 5/32"	12'
OTC	Outside trim corner —roof	3" x 7"	16" x 16"
OTCR	Outside trim corner reversed —roof	3" x 7"	16" x 16"
HS-*	H-strip	5" x 4 5/32"	12'
CP	Cover plate	6"	12'
Special Trim Items (optional)			
GS	Gravel stop	2 1/2" x 4"	12'
DS	Drip shield	1" x 2"	12'
DT-*	Deck trim	Special	12'
DTC-*	Deck trim corner	Special	16" x 16"
OTZ-*	Outside trim— Z bar configuration—roof	Special	12'
OTCZ-*	Outside trim corner— Z bar configuration—roof	Special	16" x 16"
Structural Items (optional)			
PS	Pipe support	As required	As required
IB-W	I Beam—wide flange	As required	As required
SC-*	Structural channel	As required	As required
SA 2 x 2/10	Special angle	2" x 2"	10'
SA 2 x 4/10	Special angle	2" x 4"	10'

*(-2 = 2-inch-thick panel; -4 = 4-inch-thick panel)

McGill AirSilence LLC

An enterprise of United McGill Corporation —
Founded in 1951

2400 Fairwood Avenue
Columbus, Ohio 43207-2700
614/443-5520
Fax: 614/542-2620
E-mail: acoustics@mcgillairsilence.com
Web site: mcgillairsilence.com