

Soundscreen™ Type RR (Rapid Removable) Panel Systems

a McGill AirSilence™ product

United McGill® products

McGill AirSilence's Soundscreen™ Type RR acoustic enclosures control noise at OSHA compliant levels while providing quick and easy access to internal equipment for maintenance and repair. Type RR enclosures feature a patented, lightweight, removable panel that fits into a drop-in channel frame. A bulb gasket provides the noise isolation at the panel joints. Type RR enclosures come with all the necessary trim and support frame to provide a secure and attractive, finished appearance.

Type RR enclosures are used to control noise in many industrial applications where quick access is needed for checking or maintenance. One application in particular is to enclose positive placement blowers. Noise generated from

blowers emanates from the drive. The best way to control this noise is to enclose the entire blower package, including the blower intake and discharge silencers.

Type RR enclosures not only control the noise, but also allow convenient access to the blower package and its components without having to disassemble the panels. The enclosure panels can be easily removed from their framework and re-installed as required. And since the access is from the outside, no internal walkway around the equipment is needed, **saving valuable floor space.**



Blower enclosure made with Type RR removable panel system.

The Type RR acoustical panel system allows easy access to internal equipment.

Assembly Sequence

1. Locate corner posts.
2. Set up structural framework.
3. Add lower base channel.
4. Lift side RR panels into place.
5. Add roof panels.
6. & 7. (Optional) Frame opening and install venting silencer.

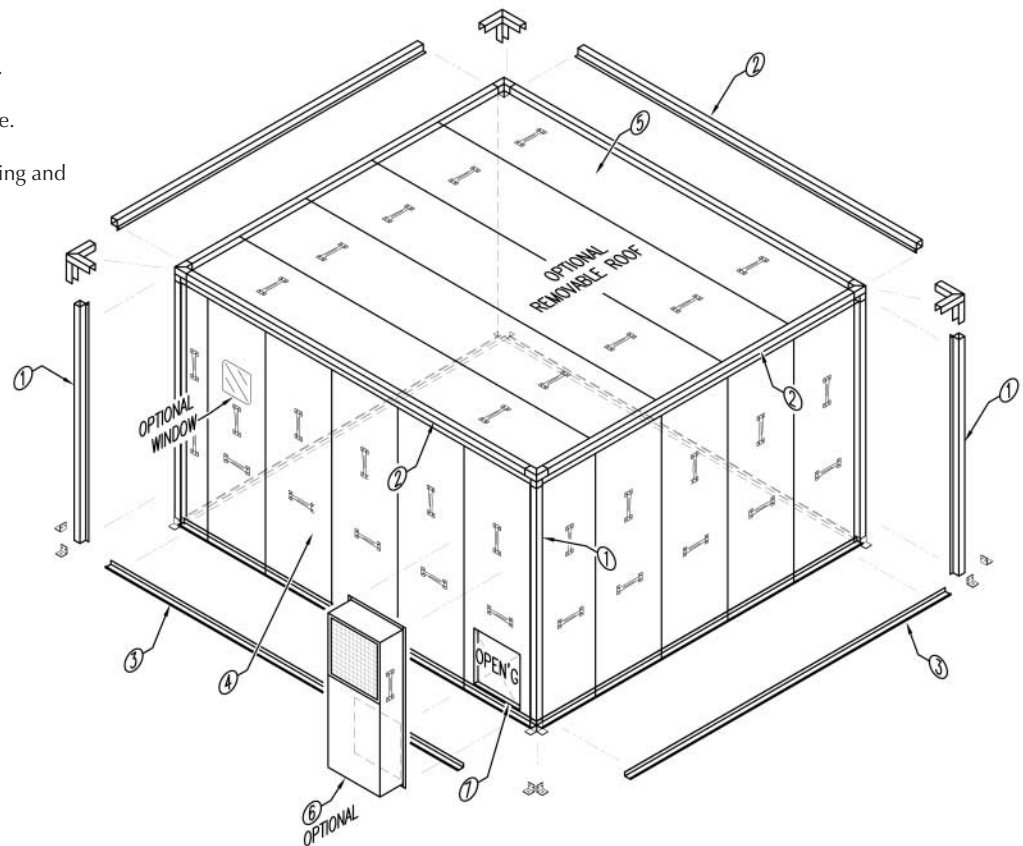

Figure 1—Assembly of typical Type RR acoustical enclosure

Performance

Depending on the application, RR panel systems can yield noise reductions of 15-25 dBA, well within acceptable levels, and provide excellent transmission loss (STC-38).

Applications

Type RR acoustical enclosures can be designed for blowers, pumps, barrier walls, machinery, equipment test booths and others.

Type RR Panel Construction

The standard Type RR panel (Figure 2) consists of a construction of either an 18- or 20-gauge, galvanized solid steel outer shell and acoustical/thermal insulating fill.

Other materials are available including paintable galvanized steel, types 304 and 316 stainless steel, and aluminum. Panels with a perforated metal inner protective barrier are available as an option.

Panel Assembly

In the Type RR panel assembly (Figure 1) the tubular steel skeleton framing system is erected first, providing the structural integrity of the system. The top and bottom channels, corner and intermediate posts, and any roof beams are field assembled. Next, the Type RR panels are lifted into the top channel, then lowered into the base channel, and pushed against the adjacent panel (Figure 3).

Joint Construction

Type RR panels require no acoustical caulking at the panel-to-panel joints because the compressed bulb gasket provides the noise isolation. Sheet metal screws are also not required at the panel-to-panel joints because the preassembled tubular frame provides the structural integrity.

Insulation

The acoustical/thermal insulating fill used in all standard Soundscreen™ Type RR panels is glass fiber insulation with an acrylic coating that minimizes loose fibers and erosion. It will not settle or promote the growth of bacteria, mold, vermin, or insects. The insulation used with the optional perforated galvanized steel inner liner is uncoated glass fiber insulation.

Surface Burning Characteristics

All insulating materials, inner and outer surfaces used in Soundscreen™ Type RR panels meet the requirements of NFPA-90A.

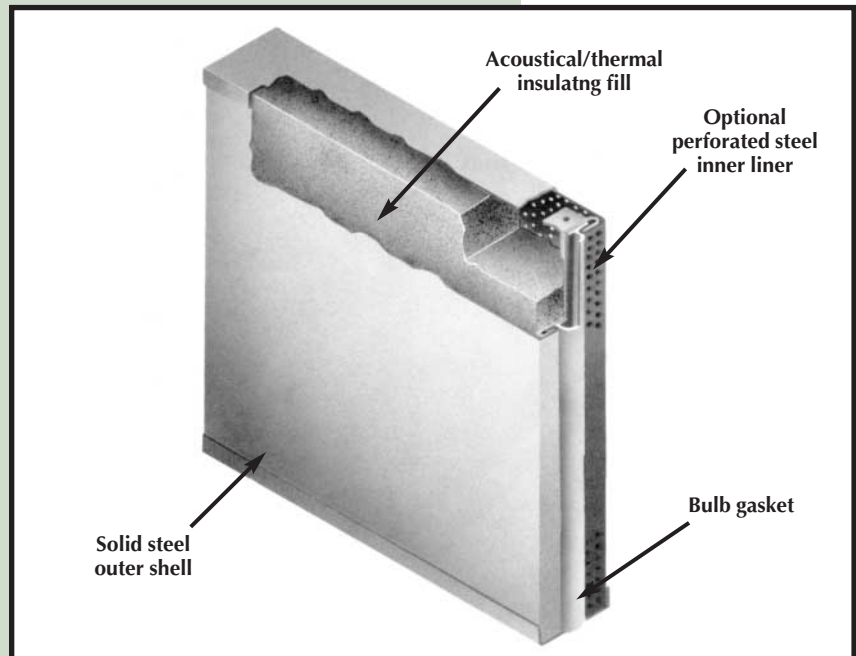

Figure 2—Standard Type RR panel construction

Type RR Panel Dimensions

| Available Thicknesses ³ | Standard Manufactured Widths ¹ | Maximum Standard Length ² |
|------------------------------------|---|--------------------------------------|
| 4 and 2 inches | up to 16 inches | 8 feet |

¹ For most assemblies, at least one panel with a nonstandard manufactured width will be required to complete the specified lengths of each wall or roof assembly.

² Longer lengths are available by special order.

³ Type RR panels in 4- and 2-inch thicknesses are provided with one bulb gasket on each length side of each panel.

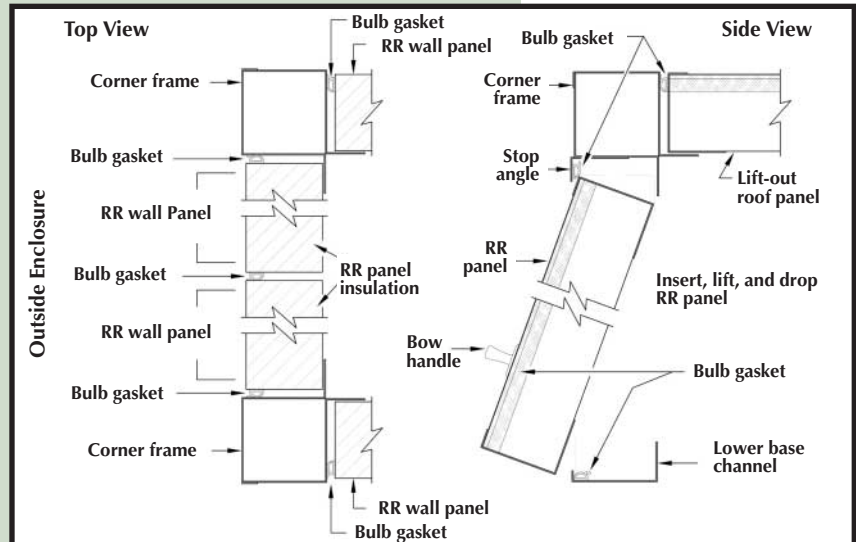

Figure 3—Assembly of Type RR panels

Products depicted in this brochure were current at the time of publication. As a quality-conscious manufacturer, McGill AirSilence is continually seeking ways to improve its products to better serve its customers. Therefore, all designs, specifications, and product features are subject to change without notice.

United McGill® and Sounpak® are registered trademarks, and McGill AirSilence™ and Soundscreen™ are trademarks of United McGill Corporation.

McGill AirSilence LLC

An enterprise of United McGill Corporation — Founded in 1951

2400 Fairwood Avenue
Columbus, Ohio 43207-2700
614/443-5520, Fax: 614/542-2620
E-mail: sales@mcgillairsilence.com
Web site: mcgillairsilence.com

Form No.: MASIL-TypeRR Rev. 1 5/07